

RECOMMENDED SPECIFICATIONS FOR COMMERCIAL STEEL DOOR AND FRAME PRODUCTS

PURPOSE

The purpose of this publication is to establish basic requirements for the specification, manufacture and installation of steel doors, frame products and related items, for the guidance of Architects, Specifiers, users and producers.

SCOPE

Members of the Canadian Steel Door Manufacturer's Association (CSDMA) utilize these Specifications as the minimum manufacturing standard for commercial, industrial, institutional and special purpose steel doors and frame products.

This publication contains information regarding materials, fabrication, handling and other related work, in accordance with Construction Specifications Canada's format for the National Master Specification (NMS), except where otherwise indicated.

Each Specification contains certain options and items not applicable to every project. Therefore, they are not intended to be duplicated verbatim, but to be selectively edited and compiled, after due consideration of all factors relating to performance, function and architectural requirements.

All dimensions indicated are nominal. Requirements are stated in both imperial and corresponding hard metric values. Each is considered the standard for its measurement system. Specifiers are advised not to mix measurement systems. All products, constructions and options included in this publication are not necessarily available from each member manufacturer. Architects and Specifiers are encouraged to contact member manufacturers to assist in product selection to meet their project requirements.

**CANADIAN
STEEL DOOR
MANUFACTURERS
ASSOCIATION**

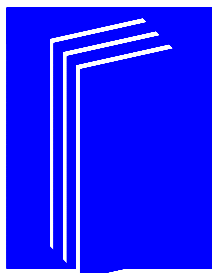

**L'ASSOCIATION
CANADIENNE
DES FABRICANTS
DE PORTES**

CONTENTS

Purpose and Scope	Cover
Contents	1
Preface	2
Section 08 11 13 - Steel Doors and Frames	3
Part 1 - General	3
1.1 Work Included	3
1.2 Related Sections	3
1.3 Defining Opening Sizes	3
1.4 References	4
1.5 Submittals	4
1.6 Warranty	5
Part 2 - Products	5
2.1 Materials	5
2.1.1 Acceptable Materials	5
2.1.2 Steel	5
2.1.3 Door Core Materials - Standard	5
2.1.4 Door Core Materials - Optional	5
2.1.5 Primers	6
2.1.6 Miscellaneous	6
2.2 Fabrication - Frame Product	6
2.2.1 General	6
2.2.2 Welded Type	7
2.2.3 Knocked-Down Type	8
2.2.4 Slip-On Type	8
2.3 Fabrication - Doors	8
2.3.1 General	8
2.3.2 Laminated Core Construction	9
2.3.3 Welded Stiffener Construction	10
Part 3 - Execution	10
3.1 Site Storage and Protection of Materials	10
3.2 Installation	10
Section 08 11 19 - Stainless Steel Doors and Frames	12
Section 08 34 49 - Lead-Lined Steel Doors and Frames	15
Section 08 34 73 - Sound Retardant Steel Door and Frame Assemblies	18
Section 08 39 53 - Blast Retardant Steel Door and Frame Assemblies	20
Table 1 - Minimum Gauges for Component Parts	23
Appendix 1 - Steel Thickness and Gauges	24
Appendix 2 - Welded Frame Types	25
CSDMA Membership	Back Cover

PREFACE

The CSC/NMS Master Format has gone through a major restructuring. The new format, based on a six (6) digit Section designation system, called "Master Format 2004", is utilized in this publication. Steel doors and frames previously included in Section 08110, 08111 and 08112 are now under 08 11 13.

To assist Architects and Specifiers in the transition, the Table below provides a cross-referencing for the CSC/CSI Master Format 2004 and the previous CSC/NMS and Buildcore Section designations.

Section Title	CSC/CSI Master Format 2004	CSC/NMS Master Format 1995	Buildcore
Metal Doors and Frames	08 11 00	-	08100
Steel Doors and Frames	08 11 13	08110	-
Steel Fire-Rated Doors and Frames	-	08110	08105
Steel Hollow Metal Doors	08 13 13	08112	-
Standard Steel Doors	08 13 13.13	-	08110
Custom Steel Doors	08 13 13.53	-	08112
Steel Hollow Metal Frames	08 12 13	08111	-
Standard Steel Frames	08 12 13.13	-	08111
Custom Steel Frames	08 12 13.53	-	08113
Steel Windows	08 51 23	-	08510

The CSC/CSI Master Format 2004 Section numbering is also utilized when compiling Specifications for "special purpose" steel door and frame products. Specification outlines for the constructions listed below are found on pages 12 to 22 of this publication.

In addition, individual electronic (Word for Windows format) versions of each of the five specifications included in this publication are available from the CSDMA website (www.csdma.org). Each is pre-compiled, can be down-loaded, edited and utilized as project and/or office master specifications.

Section Title	CSC/CSI Master Format 2004 & CSDMA 2006	NMS Master Format 1995	Buildcore
Stainless Steel Doors and Frames	08 11 19	08130	08130
Lead Lined Doors and Frames	08 34 49	-	08300
Sound Retardant Doors and Frames	08 34 73	-	08380
Blast Retardant Doors	08 39 53	-	08315

Italicized text under the heading "Spec Note" is intended for the guidance of the Specifier, and should not appear in project Specifications.

**SPECIFICATIONS - SECTION 08 11 13
 STEEL DOORS AND FRAMES**

SPEC NOTE: Coordinate design and drawing requirements and Related Work of other Sections with the following CSDMA publications:

- "Recommended Dimensional Standards for Commercial Steel Doors and Frames"
- "Selection and Usage Guide for Steel Doors and Frames"
- "Canadian Fire Labeling Guide"

PART 1 - GENERAL

1.1 Work Included

As detailed or scheduled in the contract documents, supply only of:

- .1 Steel frame products including frames, transom frames (glazed or paneled), sidelight and window assemblies, fire-rated and non-rated.
- .2 Steel panels, fixed or removable, flush or rabbetted, similar in construction to steel doors, for use in steel frame product.

SPEC NOTE: 'Flush' doors are defined as those without visible seams on faces of doors.

- .3 Steel doors, swing type, flush, with or without embossed face sheets, with or without glazed or louvered openings, fire-rated, with or without temperature rise ratings, and non-rated.

1.2 Related Sections

.1 Building-in [and grouting] frame product into masonry	04 05 00
.2 Building-in frame product in [wood] [steel] stud walls	[06 10 00] [09 20 00]
.3 Installation of doors and hardware	06 20 00
.4 Drilling and tapping of doors and frame product for surface mounted hardware	06 20 00
.5 Caulking of joints between frame product and other building components	07 90 00
.6 Stainless steel doors and frame product	08 11 19
.7 Sound retardant steel door and frame assemblies	08 34 73
.8 Lead-lined steel doors and frames	08 34 49
.9 Blast retardant steel door and frame assemblies	08 39 53
.10 Builders hardware	08 71 00
.11 Weather stripping and seals	08 71 00
.12 Glass and glazing materials	08 80 00
.13 Louvers and vents	[08 90 00] [08 91 26]
.14 Field painting	09 90 00
.15 Wiring and/or conduit for electronic hardware	[]
.16 Assembly of knocked-down or slip-on frames	[]
.17 Field measurements	[]
.18 Insulation of exterior frame product perimeter members	[]
.19 Fasteners for frame product in previously placed concrete, masonry or structural steel	[]
.20 Lintels, posts, columns, or other load bearing elements	[]

1.3 Defining Opening Sizes

SPEC NOTE: See the CSDMA publication, "Recommended Dimensional Standards for Commercial Steel Doors and Frames", for detailed listings of standard Metric (SI) and Imperial sizes. Non-standard (custom) metric and imperial sizes are available. Metric and imperial sizes should not be mixed.

- 1.3.1 Width - Widths of openings shall be measured from inside to inside of frame jamb rabbets. (Referred to as "frame rabbet width" or "nominal door width")
- .2 Height - Heights of openings shall be measured from the finished floor (exclusive of floor coverings) to the head rabbet of the frame. (Referred to as "frame rabbet height" or "nominal door height")
- .3 Door Sizes - Doors shall be sized so as to fit the above openings and allow a 3 mm (0.125") nominal clearance at jambs and head of frame. A clearance of 19 mm (0.75") maximum shall be allowed between the bottom of the door and the finished floor (exclusive of floor coverings).
- .4 Tolerances - Doors and frame product shall be manufactured and installed in accordance with the CSDMA's, "Recommended Dimensional Standards for Commercial Steel Doors and Frames".

1.4 References

SPEC NOTE: The publications listed in Section 1.4 form part of this Specification to the extent referenced. The publications are referenced in the text by basic designation only. When a more recent Standard is available, the Specifier must verify its applicability to the Specification prior to its inclusion.

- .1 ANSI/NFPA 80-1999, Standard for Fire Doors and Fire Windows
- .2 ASTM A653/A653M-05a, Specification for Steel Sheet, Zinc-Coated (Galvanized) or Zinc-Iron Alloy Coated (Galvannealed) by the Hot-Dip Process
- .3 ASTM C553-02, Specification for Mineral Fiber Blanket Insulation for Commercial and Industrial Applications
- .4 ASTM C578-05, Specification for Rigid, Cellular Polystyrene Thermal Insulation
- .5 ASTM C591-01, Specification for Un-Faced Pre-formed Rigid Cellular Polyisocyanurate Thermal Insulation
- .6 ASTM C592-04, Specification for Mineral Fiber Batt and Blanket Thermal Insulation for Light Frame Construction
- .7 ASTM C1289-05a, Specification for Faced Rigid Cellular Polyisocyanurate Thermal Insulation Board
- .8 CAN4-S104-M80, Standard Method for Fire Tests of Door Assemblies
- .9 CAN4-S106-M80, Standard Method for Fire Tests of Window and Glass Block Assemblies
- .10 CGSB 41-GP-19MA (1984), Rigid Vinyl Extrusions for Windows and Doors
- .11 CSA W59-2003, Welded Steel Construction (Metal Arc Welding)
- .12 CSDMA, Recommended Dimensional Standards for Commercial Steel Doors and Frames, 2000
- .13 CSDMA, Selection and Usage Guide for Steel Doors and Frames, 1990
- .14 CSDMA, Recommended Specifications for Commercial Steel Door and Frame Products - 08 11 00, 2006

SPEC NOTE: The approved submittal drawings and the approved hardware schedule are the versions that have been provided to the contractor responsible for supply of steel door and frame products at the time of release for fabrication. These drawings and schedules are considered part of the contract documents.

1.5 Submittals

- .1 Submit shop drawings in accordance with Section 01 33 23.
- .2 Indicate each type of door, frame, steel, construction and core.
- .3 Indicate material thickness, mortises, reinforcements, anchorages, locations of exposed fasteners, openings (glazed, paneled or louvered) and arrangement of standard hardware.
- .4 Include schedule identifying each unit, with door marks and numbers relating to numbering on drawings and door schedule of the Architect.

- 1.5.5 Contractor responsible for coordination and installation of products provided under this Section shall;
- .1 Verify and provide to the contractor responsible for the supply of steel door and frame products, actual opening sizes and field conditions by field measurement before fabrication. Submittal drawings shall reflect measurements and conditions provided, and product manufactured accordingly. Coordinate field measurements with fabrication and construction schedules to avoid delays.
 - .2 Verify that substrate conditions, whether existing or installed under other Sections, are as detailed in the Architect's drawings, and are acceptable for product installation in accordance with the manufacturer's instructions.
 - .6 Manufacturer shall not proceed with fabrication without receipt of approved submittal drawings and approved hardware schedule.
- 1.6 Warranty
 Materials and workmanship shall be warranted by the manufacturer for a period of one (1) year from date of shipment, when stored and installed in accordance with the manufacturer's recommendations, and Sections 3.1 and 3.2 of this Specification.

PART 2 - PRODUCTS

- 2.1 Materials
- .1 Acceptable Materials
 Steel doors and frame product manufactured in accordance with this Specification by CSDMA members, are eligible for use on this project.
SPEC NOTE: Heavier galvanized coatings (reference ASTM A653) are available for specialized applications.
 - .2 Steel
 Commercial grade steel to ASTM A653, CS, Type B, Coating Designation ZF75 (A25) minimum. Minimum steel thicknesses shall be in accordance with Appendix 1 of the CSDMA, "Recommended Specifications for Commercial Steel Door and Frame Products".
 - .3 Door Core Materials - Standard
 - .1 Honeycomb
 Structural small cell 25.4 mm (1") maximum kraft paper 'honeycomb'. Weight: 36.3 kg (80 lb.) per ream minimum, density: 16.5 kg/m³ (1.03 pcf) minimum, sanded to required thickness.
 - .2 Fiberglass
 Loose batt type, density 24 kg/m³ (1.5 pcf) minimum, conforming to ASTM C553 or ASTM C592.
 - .3 Polystyrene
 Rigid extruded fire retardant, closed cell board. Density; 16 to 32 kg/m³ (1 to 2 pcf), thermal values; RSI 1.0 (R 6.0) minimum, Type 1, in accordance with ASTM C578.
 - .4 Door Core Materials - Optional
 - .1 Polyisocyanurate
 Rigid, modified polyisocyanurate, closed cell board. Density; 32 kg/m³ (2.0 pcf) minimum, thermal values; RSI 1.9 (R 11.0) minimum, in accordance with ASTM C591 (un-faced) or C 1289 (faced).
 - .2 Temperature Rise Rated (TRR)
 Core composition to provide the fire-protection rating and limit the temperature rise on the unexposed side of door to 250°C at 30 or 60 minutes, as determined by governing building

code requirements. Core to be tested as part of a complete door assembly, in accordance with CAN4-S104, covering the Standard Method of Tests of Door Assemblies and shall be listed by a nationally recognized testing agency having a factory inspection service.

2.1.5 Primers

Rust inhibitive touch-up only.

.6 Miscellaneous

.1 Door Silencers

Single stud rubber/neoprene type.

.2 Exterior Top Caps

Rigid polyvinylchloride extrusion conforming to CGSB 41-GP-19MA.

.3 Frame Thermal Breaks

Rigid polyvinylchloride extrusion conforming to CGSB 41-GP-19MA.

2.2 Fabrication - Frame Products

SPEC NOTE: "Frame Products" include steel frames, transom frames, sidelight and window assemblies. Section 2.2.1 applies to all construction 'types', unless indicated otherwise.

.1 General

SPEC NOTE: 14 gauge knocked-down frames are not generally available. Refer to the CSDMA, "Selection and Usage Guide for Steel Doors and Frames", and Table 1 of the CSDMA, "Recommended Specifications for Commercial Steel Door and Frame Products" for guidance on the selection of appropriate frame gauges.

- .1 Exterior frame product shall be [14] [16] gauge. Exterior frames shall be [welded] [knocked-down] type construction [, thermally broken]. Exterior transom frames, sidelight and window assemblies shall be welded type construction [, thermally broken]. Interior frame product shall be [16] [18] gauge. Interior frames and window assemblies shall be [welded] [knocked-down] [slip-on] type construction. Interior transom frames shall be [welded] [knocked-down] type construction. Interior sidelight assemblies shall be welded type construction.
- .2 Frame product shall be mortised, blanked, reinforced, drilled and tapped at the factory for templated hardware only, in accordance with the approved hardware schedule and templates provided by the hardware supplier.
- .3 Mortised cutouts shall be protected with steel guard boxes (may be omitted on dry wall applications).
- .4 Frame product shall be reinforced only, where required, for surface mounted hardware, anchor hinges, thrust pivots, pivot reinforced hinges, or non-templated hardware. Drilling and tapping is by others, on site, at time of installation.
- .5 Provide anchorage appropriate to floor, wall and frame construction. Each wall anchor shall be located immediately above or below each hinge reinforcement on the hinge jamb and directly opposite on the strike jamb. For rebate opening heights up to and including 1520 mm (60") provide two (2) anchors, and an additional anchor for each additional 760 mm (30") of height or fraction thereof, except as indicated below. Frames in previously placed concrete, masonry or structural steel shall be provided with anchors located not more than 150 mm (6") from the top and bottom of each jamb, and intermediate anchors at 660 mm (26") on centre maximum. Fasteners for such anchors shall be provided by others.
- .6 Minimum reinforcing, anchor and other component gauges shall be in accordance with Table 1 of the CSDMA, "Recommended Specifications for Commercial Steel Door and Frame Products".

- 2.2.1.7 Each door opening shall be prepared for single stud rubber door silencers, three (3) for single door openings, two (2) for double door openings, except on gasketed frame product.
- .8 Provide factory-applied touch up primer at areas where zinc coating has been removed during fabrication.

SPEC NOTE: The following are not generally available as fire-rated product: thermally broken frame product, or louvers or dampers in transoms, sidelights or windows. Fire-rated transom frames, sidelight and window assemblies are generally available only as welded type product.

- .9 Fire-rated frame products shall be provided for those openings requiring fire protection as determined and scheduled by the Architect. Frames, transom and sidelight assemblies shall be listed for conformance with CAN4-S104. Window assemblies shall be listed for conformance with CAN4-S106. All fire-rated frame products shall bear the label of, and be listed by a nationally recognized testing agency having a factory inspection service. Labeling shall be in accordance with NFPA 80, the listing authority's policies and label materials, and shall identify the manufacturer. Fire-rated frame products shall be constructed as listed for labeling in the Follow-Up Service Procedures/Factory Inspection Manuals issued by the listing agency to individual manufacturers.

2.2.2 Welded Type

- .1 Frame product shall be accurately mitered or mechanically jointed.

SPEC NOTE: Refer to Appendix 2 of the CSDMA, "Recommended Specifications for Commercial Steel Door and Frame Products", for illustrations of the weld types defined below. Edit 2.2.2.2 to include only those constructions referenced in 2.2.1.1.

- .2 As defined in Appendix 2 of the CSDMA, "Recommended Specifications for Commercial Steel Door and Frame Products", frame product perimeter corner joints shall be:
- [.1 Profile welded; punch-mitered - continuously welded on the profile faces, rabbets, returns and soffit intersections, or saw-mitered - continuously welded on the profile faces, rabbets, returns, stops and soffit intersections. Punch or saw-mitered, at the manufacturer's discretion. All profile welded frame product exposed faces shall be filled and ground to a smooth, uniform, seamless surface.]
 - [.2 Face welded; continuously welded on the profile faces, with exposed faces filled and ground to a smooth, uniform, seamless surface.]
 - [.3 Tack welded; welded on the faces and returns, with exposed hairline joint intersections.]
- .3 Joints at mullions, sills and center rails shall:
- .1 Be coped accurately, butted and tightly fitted.
 - .2 At intersecting flush profile faces, be securely welded, filled and ground to a smooth, uniform, seamless surface.
 - .3 At intersecting recessed profile faces, be securely welded to concealed reinforcements, with exposed hairline face seams.
 - .4 At all other intersecting profile elements, have exposed hairline face seams.
- .4 Welding shall conform to CSA W59.
- .5 Where frame product is to be installed prior to the adjacent partition, a floor anchor shall be securely attached to the inside of each jamb profile. Each floor anchor shall be provided with two (2) holes for securing to the floor. For conditions that do not permit the use of a floor anchor, an additional wall anchor, located within 150 mm (6") of the base of the jamb, shall be substituted.
- .6 Weld in two (2) temporary jamb spreaders per door opening to maintain proper alignment during shipment and handling, which shall not be used for installation.

- 2.2.2.7 Glazing stops shall be formed steel channel, minimum 16 mm (0.625") height, accurately fitted, butted at corners and fastened to frame sections with counter-sunk oval head sheet metal screws.
- .8 When required due to site access, when advised by the contractor responsible for coordination or installation, as specified on the Architect's drawings or due to shipping limitations, frame product for large openings shall be fabricated in sections as designated on the approved submittal drawings, with splice joints for field assembly and welding by others.
- .9 Prior to shipment, mark each frame product with an identification number as shown on the approved submittal drawings.

2.2.3 Knocked-Down Type

SPEC NOTE: Include 2.2.3 only if referenced in 2.2.1.1. Components for knocked-down type frames are intended to be assembled as a complete unit prior to installation.

- .1 Knocked-down type frames shall be shipped unassembled.
- .2 Frames shall have mechanical joints which inter-lock securely and provide functionally satisfactory performance when assembled and installed in accordance with the manufacturer's published instructions.
- .3 Where frame product is to be installed prior to the adjacent partition, a floor anchor shall be securely attached to the inside of each jamb profile. Each floor anchor shall be provided with two (2) holes for securing to the floor. For conditions that do not permit the use of a floor anchor, an additional wall anchor, located within 150 mm (6") of the base of the jamb, shall be substituted.
- .4 Prior to shipment, components shall be designated with an identifier corresponding to the numbering on the approved submittal drawings.

2.2.4 Slip-On Type

SPEC NOTE: Include 2.2.4 only if referenced in 2.2.1.1. Components for slip-on type frames are intended for installation in a rough stud opening after drywall has been applied. Slip-on type construction is not generally available for transom, sidelight or other than 4-sided window assemblies. Vertically stiffened and TRR doors are not recommended for use in slip-on type construction frames.

- .1 Slip-on type frames shall be shipped unassembled.
- .2 Frames shall have mechanical joints which inter-lock securely and provide functionally satisfactory performance when installed in accordance with the manufacturer's published instructions.
- .3 Slip-on frames shall be provided with manufacturer's proprietary design of wall anchorage comprising single, adjustable tension type per jamb and provision for secure attachment of each jamb base to stud runners.
- .4 Prior to shipment, components shall be designated with an identifier corresponding to the numbering on the approved submittal drawings.

2.3 Fabrication - Doors

SPEC NOTE: Section 2.3.1 applies to all construction 'types', unless otherwise indicated.

- .1 General
- .1 Exterior doors shall be [laminated core] [welded stiffener] construction.
- .2 Interior doors shall be [laminated core] [welded stiffener] construction.

SPEC NOTE: Specify longitudinal edge seams as either visible or not visible.

- 2.3.1.3 Longitudinal edges shall be [[mechanically inter-locked] [mechanically inter-locked, adhesive assisted] [mechanically interlocked, tack welded at top and bottom of door, above and below each edge cutout and at 150 mm (6") on center] with visible edge seams]] [[tack welded at top and bottom of door, above and below each edge cutout and at 150 mm (6") on center, filled and sanded] [continuously welded, filled and sanded] with no visible edge seams]].
- .4 Doors shall be mortised, blanked, reinforced, drilled and tapped at the factory for templated hardware only, in accordance with the approved hardware schedule and templates provided by the hardware supplier.
 - .5 Holes 12.7 mm (0.5") diameter and larger shall be factory prepared, except mounting and through-bolt holes, which are by others, on site, at time of hardware installation. Holes less than 12.7 mm (0.5") diameter shall be factory prepared only when required for the function of the device (for knob, lever, cylinder, thumb or turn pieces) or when these holes over-lap function holes.
 - .6 Doors shall be reinforced only, where required, for surface mounted hardware, anchor hinges, thrust pivots, pivot reinforced hinges, or non-templated hardware. Drilling and tapping is by others, on site, at time of installation.
 - .7 Top and bottom of doors shall be provided with inverted, recessed, welded steel channels. Exterior doors, and where otherwise scheduled by the Architect, shall be provided with flush [PVC] [steel] top caps.
 - .8 Minimum reinforcing and component gauges shall be in accordance with Table 1 of the CSDMA, "Recommended Specifications for Commercial Steel Door and Frame Products".
 - .9 Provide factory-applied touch-up primer at areas where zinc coating has been removed during fabrication.
 - .10 Fire-rated doors shall be provided for those openings requiring fire protection and temperature rise ratings, as determined and scheduled by the Architect. Such products shall be listed for conformance with CAN4-S104. All fire-rated doors shall bear the label of, and be listed by a nationally recognized testing agency having a factory inspection service. Labeling shall be in accordance with NFPA 80, the listing authority's policies and label materials, and shall identify the manufacturer. Fire-rated doors shall be constructed as listed for labeling in the Follow-Up Service Procedures/Factory Inspection Manuals issued by the listing agency to individual manufacturers.
 - .11 Prior to shipment, mark each door with an identification number as shown on the approved submittal drawings.

2.3.2 Laminated Core Construction

*SPEC NOTE: Refer to the CSDMA publication, "Selection and Usage Guide for Steel Doors and Frames", for guidance on the selection of appropriate face sheet gauges. For core materials, 'Honeycomb' or 'Polystyrene' are standard (ref 2.1.3). For insulated doors specify polystyrene or polyisocyanurate cores (ref 2.1.4.1 or 2.1.4.2). For temperature rise rated doors specify TRR core, and 16 or 18 gauge face sheets (ref 2.1.4.3). **Laminated vertical stiffener core doors are not considered to be thermally insulated.** Thermally broken doors are not available.*

- .1 Both face sheets for exterior doors shall be formed from a sheet of [14] [16] [18] gauge steel with [honeycomb] [polystyrene] [polyisocyanurate] [vertical steel stiffener] core, laminated under pressure to face sheets.
- .2 Both face sheets for interior doors shall be formed from a sheet of [14] [16] [18] [20] gauge steel with [honeycomb] [polystyrene] [vertical steel stiffener] core (or temperature rise rated core where specified), laminated under pressure to face sheets.

SPEC NOTE: 2.3.2.3 and 2.3.2.4 are applicable for laminated, vertical steel stiffener core construction doors only.

2.3.2.3 Vertical steel stiffeners shall be securely laminated to each face sheet at 150 mm (6") on center maximum.

.4 Voids between vertical stiffeners shall be filled with fiberglass batt type insulation.

2.3.3 Welded Stiffener Construction

*SPEC NOTE: Refer to the CSDMA publication, "Selection and Usage Guide for Steel Doors and Frames", for guidance on the selection of appropriate face sheet gauges. **Welded stiffener construction doors are not considered to be thermally insulated.***

.1 Both face sheets for exterior doors shall be formed from a sheet of [14] [16] [18] gauge steel.

.2 Both face sheets for interior doors shall be formed from a sheet of [14] [16] [18] gauge steel.

SPEC NOTE: Spot welding leaves small marks in the face of welded stiffener construction doors which may be visible after the application of finish paint. Their removal is difficult and may be impractical. These are inherent in the product and are not to be considered as manufacturing defects. The use of translucent paints, paints with a gloss rating greater than 20% when measured with a 60° gloss meter, or dark colours, are not recommended. Where aesthetics are seen as a more critical issue, the Specifier should consider utilizing laminated core construction.

.3 Doors shall be reinforced with vertical stiffeners, securely welded to each face sheet at 150 mm (6") on center maximum.

.4 Voids between vertical stiffeners shall be filled with fiberglass batt type insulation.

PART 3 - EXECUTION

3.1 Site Storage and Protection of Materials

SPEC NOTE: Site storage and the protection of materials are not the responsibility of the steel door and frame manufacturer. The following is provided for the direction of the contractor responsible for site storage and protection of materials.

.1 Doors and frame product shall be removed from their wrappings or coverings upon receipt on site, be stored in a vertical position, and be spaced with blocking to permit air circulation between them.

.2 All materials shall be thoroughly inspected upon receipt and all discrepancies, deficiencies and/or damages shall be immediately reported, in writing, to the supplier.

.3 All damages incurred during shipment shall be noted on the carrier's Bill of Lading and immediately reported, in writing, to the supplier.

.4 Any scratches or disfigurement of doors or frame product caused by shipping or handling shall be promptly cleaned and touched-up with a zinc-rich primer.

.5 All materials shall be properly stored on planks or dunnage, out of water and covered to protect from damage from any cause.

3.2 Installation

SPEC NOTE: Refer to the manufacturer's installation instructions for Slip-On type frames for detailed recommendations. Installation is not the responsibility of the steel door and frame manufacturer. The following is provided as recommendations for the contractor responsible for installation of these products.

- 3.2.1 Prior to installation, remove temporary shipping spreaders.
- .2 Prior to installation, the area of floor on which the frame is to be installed, and within the path of the door swing, shall be checked and corrected for flatness.
- .3 Door and frame product shall be checked for correct size, swing, rating and opening number.
- .4 The supplier shall be advised of any discrepancies prior to installation.
- .5 Set frames plumb, square, level and at correct elevation.
- .6 Fire-rated door and frame product shall be installed in accordance with the terms of their listings, NFPA-80, or the local Authority Having Jurisdiction (AHJ).
- .7 Secure anchorages and connections to adjacent construction.
- .8 Brace frames rigidly in position while building-in. Install wood spreaders at third points of frame rebate height to maintain frame width. Provide vertical support at centre of head for openings exceeding 1200 mm (48") in width.
- .9 During the setting of frame product, check and correct as necessary for opening width, opening height, square, alignment, twist and plumb, in accordance with the CSDMA, "Recommended Dimensional Standards for Commercial Steel Doors and Frames".
- .10 Remove wood spreaders after frames have been built-in.

SPEC NOTE: The use of water based masonry grout, with or without antifreeze agents, should be carefully weighed during the specification process. The grouting of mullions and other closed sections is not recommended, and plaster based grouts should not be used. Grouting is not required for fire-rated frame product.

- .11 Make allowance for deflection to ensure structural loads are not transmitted to frame product.
- .12 Install doors, and hardware in accordance with hardware templates and manufacturer's instructions.
- .13 Adjust operable parts for correct clearances and function.
- .14 Install louvers, glazing and door silencers.
- .15 Finish paint in accordance with Section 09 90 00.

END OF SECTION 08 11 13

**SPECIFICATIONS - SECTION 08 11 19
 STAINLESS STEEL DOORS AND FRAMES**

SPEC NOTE: When compiling Specifications for stainless steel doors and frames, modify the CSDMA, "Recommended Specifications for Commercial Steel Door and Frame Products", Section 08 11 13, Parts 1 through 3, as indicated below.

- Substitute: Section Heading "08 11 13" with:
 08 11 19
 Section Name "STEEL DOORS AND FRAMES" with:
 STAINLESS STEEL DOORS AND FRAMES
- Add: 1.1 *SPEC NOTE: Stainless steel clad door and frame product are not recommended for exterior applications. Edit Section 08 11 19 references to "manufactured from" versus "clad with" stainless steel, as appropriate.*
- Substitute: 1.1.1 Stainless steel [clad] frame products, including frames, transom frames (glazed or paneled), sidelight and window assemblies, fire-rated and non-rated.
 1.1.2 Stainless steel [clad] panels, fixed or removable, flush or rabbeted, similar in construction to stainless steel [clad] doors, for use in stainless steel frame product.
 1.1.3 Stainless steel [clad] doors, swing type, flush, with or without glazed or louvered openings, fire-rated and non-rated.
 1.2.6 Steel Doors and Frames 08 11 13
- Delete: 1.2.14 Field Painting 09 90 00
- Re-Number: 1.2.15 through 1.2.20 to 1.2.14 through 1.2.19
- Add: 1.4.3 ASTM A666-03, Specification for Annealed or Cold-Worked Austenitic Stainless Steel Sheet, Strip, Plate and Flat Bar
- Re-Number: 1.4.3 through 1.4.10 to 1.4.4 through 1.4.11
- Delete: 1.4.11 Welded Steel Construction
- Substitute: 1.5.3 Indicate material type, finish and thickness, mortises, reinforcements, anchorages, locations of exposed fasteners, openings (glazed, paneled or louvered) and arrangement of standard hardware.
 2.1.2 Spec Note on "heavier galvanized coatings" with:
SPEC NOTE: Doors and frame product are manufactured from two types of stainless steel. Type 304, with galvanneal internal components, is recommended for most typical commercial applications where aesthetics is the primary design consideration. Include 2.1.2.1 for this application. Type 316, with Type 316 internal components, should be specified where corrosion resistance is the primary concern, as in areas such as public swimming pools, which are highly chlorinated. Include 2.1.2.2 only in such instances. Stainless steel Types and Finishes are specified independent of each other. Both Types are available in 2B (mill) up to 'Excelsior' XL Buff (mirror) finishes. Clad construction should only be used for interior, aesthetic applications.
- [2.1.2.1 Door face [sheets] [cladding], frame [members] [cladding], glazing trim and stops shall be stainless steel to ASTM A666, Type 304, [2B] [4] ['Excelsior' XL Blend S] ['Excelsior' XL Buff] Finish. Balance of components[, base door face sheets and base frame members for stainless steel clad product] shall be commercial grade steel to ASTM A653, CS, Type B, coating designation ZF75 (A25) minimum.]
- Add: [2.1.2.2 Door face sheets, frame members, internal components, glazing trim and stops shall be stainless steel to ASTM A666, Type 316. Door face sheets, frame members,

glazing trim and stops shall be [2B] [4] ['Excelsior' XL Blend S] ['Excelsior' XL Buff] Finish. Internal components shall be 2B (mill) Finish.]

- Add: 2.1.2.3 Minimum steel thicknesses shall be in accordance with Appendix 1 of the CSDMA, "Recommended Specifications for Commercial Steel Door and Frame Products".
- Delete: 2.1.4.2 Temperature Rise Rated Core
- Add: 2.1.5 *SPEC NOTE: 2.1.5 is applicable to base door and frame of stainless steel clad product only. Delete where product is manufactured from stainless steel.*
- Substitute: 2.2.1.1 *SPEC NOTE: Frame product manufactured from 'Excelsior' XL Buff (mirror) Finish stainless steel is not available in face welded type construction due to limitations in re-finishing welded areas. Refer to the CSDMA, "Selection and Usage Guide for Steel Doors and Frames", for guidance on the selection of appropriate frame gauges.*
 - 2.2.1.1 Exterior frame product shall be 16 gauge. Exterior frames shall be [welded] [knocked-down] type construction[, thermally broken]. Exterior transom frames, sidelight and window assemblies shall be welded type construction[, thermally broken]. [Sub-frame for] stainless steel [clad] interior frame product shall be 16 gauge. [Sub-frame for] stainless steel [clad] interior frames and window assemblies shall be [welded] [knocked-down] [slip-on] type construction. Interior transom frames shall be [welded] [knocked-down] type construction. Interior sidelight assemblies shall be welded type construction. [Cladding for all frame product shall be 18 gauge.]
 - 2.2.1.8 Direction of stainless steel grain shall be vertical on frame faces.
 - 2.2.2.2 Spec Note with:
Edit 2.2.2.2 to include either product fabricated from or clad in stainless steel.
 - [2.2.2.2 Perimeter corner joints of stainless steel frame product:
 - [2.2.2.2.1 Fabricated from other than 'Excelsior' XL Buff (mirror) finish stainless steel shall be continuously welded on the profile faces, with exposed faces ground to a smooth, uniform, seamless surface.]
 - [2.2.2.2.2 Fabricated from 'Excelsior' XL Buff (mirror) finish stainless steel shall be provided with internal reinforcing gussets or plates securely attached to each section, or integral tabs and slots. Gussets, plates or tabs shall be internally welded to the mating section with visible hair-line joints.]]
 - or*
 - [2.2.2.2 As defined in Appendix 2 of the CSDMA, "Recommended Specifications for Commercial Steel Door and Frame Products", perimeter corner joints of sub-frame for stainless steel clad frame product shall be;
 - [2.2.2.2.1 Profile welded; punch-mitered - continuously welded on the profile faces, rabbets, returns and soffit intersections, or saw-mitered - continuously welded on the profile faces, rabbets, returns, stops and soffit intersections. Punch or saw-mitered, at the manufacturer's discretion. All profile welded frame product sub-frame exposed faces shall be ground to a smooth, uniform, seamless surface.]
 - [2.2.2.2.2 Face welded; continuously welded on the profile faces, with sub-frame exposed faces ground to a smooth, uniform, seamless surface.]
 - [2.2.2.2.3 Tack welded; welded on the profile faces and returns, with sub-frame exposed hairline joint intersections.]
 - 2.2.2.2.4 Stainless steel cladding shall be securely attached to each section, presenting visible hair-line joints.]]
 - 2.2.2.3.2 At intersecting flush profile faces, match corner joints when assembled.

- Delete: 2.2.2.4 CSA W59
- Re-Number: 2.2.2.5 and 2.2.2.6 to 2.2.2.4 and 2.2.2.5
- Re-Number: 2.2.2.7 to 2.2.2.6 and substitute:
Glazing stops shall be formed channel, matching the Type and Finish of the frame product, minimum 16 mm (0.625") height, accurately fitted, butted at corners and fastened to frame sections with counter-sunk oval head sheet metal screws.
- Re-Number: 2.2.2.8 and 2.2.2.9 to 2.2.2.7 and 2.2.2.8
- Substitute: 2.3.1.1 Doors shall be laminated core construction.
- Delete: 2.3.1.2 Interior Doors
- Re-Number: 2.3.1.3 to 2.3.1.2 and substitute:
Longitudinal edges of [base door, when clad] [doors fabricated from stainless steel] shall be [[mechanically inter-locked] [mechanically interlocked, adhesive assisted] with visible edge seams. [Clad doors shall have visible hair-line butted joints at door edges.]] [continuously welded and finished to match face sheets, with no visible edge seams.]
- Re-Number: 2.3.1.4 through 2.3.1.8 to 2.3.1.3 through 2.3.1.7
- Add: 2.3.1.8 *SPEC NOTE: 2.3.1.8 is applicable to the base door of stainless steel clad product only.*
- Re-Number: 2.3.1.9 through 2.3.1.11 to 2.3.1.8 through 2.3.1.10
- Delete: 2.3.2 Spec Note references to Temperature Rise Rated Doors
- Substitute: 2.3.2.1 Both face sheets for exterior doors shall be formed from a sheet of [16] [18] gauge stainless steel with [honeycomb] [polystyrene] [polyisocyanurate] [vertical steel stiffener] core, laminated under pressure to face sheets.
- 2.3.2.2 [Both face sheets for interior doors fabricated from stainless steel shall be formed from a sheet of [16] [18] gauge stainless steel.] [Both face sheets for interior doors to be clad in stainless steel shall be formed from a sheet of [16] [18] gage steel. Cladding shall be 18 gauge stainless steel.] Construct interior doors with [honeycomb] [polystyrene] [polyisocyanurate] [vertical steel stiffener] core laminated under pressure to face sheets.
- Add: 2.3.2.5 Direction of stainless steel grain shall be vertical on door faces and edges.
- Delete: 2.3.3 Welded Stiffener Construction
- Substitute: 3.1.4 Any scratches or disfigurement of doors or frame product caused by shipping or handling shall be refinished to their original state.
- Delete: 3.2.15 Finish Paint
From Table 1;
- Frames - Extra Heavy and Heavy Duty - 14 Gauge
- Standard Duty - 18 Gauge
- Doors - Laminated Core Construction-Face Sheets - Extra Heavy Duty - 14 Gauge
-Face Sheets - Heavy Duty - 14 Gauge
- Doors - Welded Stiffener Construction

END OF SECTION 08 11 19

**SPECIFICATIONS - SECTION 08 34 49
 LEAD-LINED STEEL DOORS AND FRAMES (FOR RADIATION SHIELDING)**

SPEC NOTE: When compiling Specifications for lead-lined steel doors and frames, modify the CSDMA, "Recommended Specifications for Commercial Steel Door and Frame Products", Section 08 11 13, Parts 1 through 3 as indicated below.

- Substitute: Section Heading "08 11 13" with:
 08 34 49
 Section Name "STEEL DOORS AND FRAMES" with:
 LEAD-LINED STEEL DOORS AND FRAMES
- 1.1.1 Lead-lined (radiation shielding) steel frame products including frames, transom frames (glazed or paneled), sidelight and window assemblies, fire-rated and non-rated.
- 1.1.2 Lead-lined (radiation shielding) steel panels, fixed or removable, flush or rabbetted, similar in construction to lead-lined steel doors, for use in frame product.
- 1.1.3 Lead-lined (radiation shielding) steel doors, swing type, flush, with or without glazed openings, fire-rated and non-rated.
- 1.2.8 Steel Doors and Frames 08 11 13
- Delete: 1.2.13 Louvers and vents [08 90 00] [08 91 26]
 1.2.16 Assembly of knocked-down or slip-on frames
- Re-Number: 1.2.14 through 1.2.20 to 1.2.13 through 1.2.18
- Substitute: 1.4.3 ASTM B29-03, Specifications for Refined Lead
 1.4.4 ASTM B749-03, Specification for Lead and Lead Alloy Strip, Sheet and Plate Products
- Delete: 1.4.5 ASTM C591
 1.4.6 ASTM C592
 1.4.7 ASTM C1289
 1.4.9 CAN4-S106
 1.4.10 CGSB 41-GP-19MA
- Re-Number: 1.4.8 through 1.4.14 to 1.4.5 through 1.4.9
- Substitute: 1.5.3 Indicate material thickness, mortises, reinforcements, anchorages, locations of exposed fasteners, glazed or paneled openings, and arrangement of standard hardware.
- Delete: 2.1.2 Spec Note on heavier galvanized coatings
- Add: 2.1.3 *SPEC NOTE: Sheet leads are specified by weight per square meter (foot) and/or nominal thickness. Commercially available sheet lead, specified for radiation shielding, conforms to the following standards:*

<u>Weight</u>	<u>Thickness</u>
9.8 kg/m ² (2 psf)	0.8 mm (.031") (1/32")
14.6 kg/m ² (3 psf)	1.2 mm (.047") (3/64")
19.5 kg/m ² (4 psf)	1.6 mm (.063") (1/16")

- Substitute 2.1.3.1 Lead
 Cast or rolled pure sheet lead meeting [ASTM B29] [ASTM B749]. Weights or thickness as specified to shield against radiation types and levels determined by the Architect or Radiation Consultant.

- Substitute: 2.1.3.2 Composites
Balance of core materials used in conjunction with lead shall be in accordance with manufacturer's proprietary design.
- Delete: 2.1.3.3 Polystyrene
2.1.4 Door Core Materials - Optional
- Re-Number: 2.1.5 to 2.1.4
- Delete: 2.1.6.2 Exterior Top Caps
2.1.6.3 Frame Thermal Breaks
- Re-Number: 2.1.6.1 to 2.1.5
- Delete: 2.2.1.1 Spec Note reference to 14 Gauge Knocked-Down Frames
- Substitute: 2.2.1.1 Frames shall be 16 gauge welded type construction. [9.9 kg/m²/0.8 mm] [14.6 kg/m²/1.2 mm] [19.5 kg/m²/1.6 mm] lead shall be securely attached to the inside of the frame profile, from return to stop/soffit intersection (inclusive), on the door side of the frame only.
- 2.2.1.9 *SPEC NOTE: The following are not available as fire-rated lead-lined product: transom frames, sidelight or window assemblies.*
- 2.2.1.9 Fire-rated lead-lined frames shall be provided for those openings requiring fire protection as determined and scheduled by the Architect. Lead-lined frames shall be listed for conformance with CAN4-S104. All fire-rated lead-lined frames shall bear the label of, and be listed by a nationally recognized testing agency having a factory inspection service. Labeling shall be in accordance with NFPA 80, the listing authority's policies and label materials, and shall identify the manufacturer. Fire-rated lead-lined frames shall be constructed as listed for labeling in the Follow-Up Service Procedures/Factory Audit Manuals issued by the listing agency to individual manufacturers.
- 2.2.2.2 Spec Note with:
Refer to Appendix 2 of the CSDMA "Recommended Specifications for Commercial Steel Door and Frame Products" for illustrations of the welded type defined below.
- 2.2.2.2 As defined in Appendix 2 of the CSDMA, "Recommended Specifications for Commercial Steel Door and Frame Products", frame product perimeter corner joints shall be profile welded; punch-mitered - continuously welded on the profile faces, rabbets, returns and soffit intersections, or saw-mitered - continuously welded on the profile faces, rabbets, returns, stops and soffit intersections. Punch or saw-mitered, at the manufacturer's discretion. All profile welded frame product exposed faces shall be filled and ground to a smooth, uniform, seamless surface.
- Delete: 2.2.2.2.3 Face Welded
2.2.2.2.4 Tack Welded
2.2.3 Knocked-Down Type
2.2.4 Slip-On Type
- Substitute: 2.3.1.1 Doors shall be laminated core construction.
- Delete: 2.3.1.2 Interior Doors
- Re-Number: 2.3.1.3 to 2.3.1.2
- Add: 2.3.1.3 *SPEC NOTE: Hardware must be carefully selected for use on lead-lined steel doors and frame product. Hinges must be specified to suit the weight and size of the doors specified. All other hardware must be lead-lined to ensure the integrity of the opening.*

- Re-Number: 2.3.1.5 and 2.3.1.6 to 2.3.1.4 and 2.3.1.5
- Re-Number: 2.3.1.7 to 2.3.1.6 and substitute:
Top and bottom of doors shall be provided with inverted, recessed, welded, lead-lined channels and flush steel top and bottom caps.
- Re-Number: 2.3.1.8 through 2.3.1.11 to 2.3.1.7 through 2.3.1.10
- Delete: 2.3.2 Spec Note references to Core Materials, Temperature Rise Rated Cores, Laminated Vertical Stiffener Cores, and Thermally Broken Doors.
- Substitute: 2.3.2.1 Both face sheets shall be formed from a sheet of [16] [18] gauge steel.
2.3.2.2 Core shall be a composite of [9.9 kg/m²/0.8 mm] [14.6 kg/m²/1.2 mm] [19.5 kg/m²/1.6 mm] sheet lead and the manufacturer's proprietary design, laminated under pressure to face sheets.
- Delete: 2.3.2.3 Spec Note on Laminated Vertical Stiffeners
2.3.2.3 Vertical Stiffeners
2.3.2.4 Insulation Between Stiffeners
2.3.3 Welded Stiffener Construction
- Substitute: 3.2 Spec Note, 1st sentence with:
SPEC NOTE: Walls systems for lead-lined steel door and frame product must provide sufficient structural stability to support the weight and operation of these assemblies. Refer to the manufacturer's installation instructions for detailed recommendations.
- Add: 3.2.5 The contractor responsible for installation shall ensure the integrity of the lead-lining between the interior of the frame and the wall assembly.
- Re-Number: 3.2.5 through 3.2.13 to 3.2.6 through 3.2.14
- Re-Number: 3.2.14 to 3.2.15 and substitute:
Install glazing materials.
- Re-Number: 3.2.15 to 3.2.16
- Delete: From Table 1;
- Frames - Standard Duty - 18 Gauge
- Doors - Laminated Core Construction - Face Sheets - Extra Heavy Duty - 14 Gauge
- Heavy Duty - 14 Gauge
- Medium Duty - 20 or 18 Gauge
- Standard Duty - 20 Gauge
- Doors - Welded Stiffener Construction

END OF SECTION 08 34 49

SPECIFICATIONS - SECTION 08 34 73
SOUND RETARDANT STEEL DOOR AND FRAME ASSEMBLIES

SPEC NOTE: When compiling Specifications for sound retardant steel door and frame assemblies, modify the CSDMA, "Recommended Specifications for Commercial Steel Door and Frame Products", Section 08 11 13, Parts 1 through 3 as indicated below.

- Substitute: Section Heading "08 11 13" with "08 34 73"
 Section Name "STEEL DOORS AND FRAMES" with:
 SOUND RETARDANT STEEL DOOR AND FRAME ASSEMBLIES
- 1.1.1 Sound retardant steel frame products, including frames, transom frames, sidelight and window assemblies, glazed or paneled, fire-rated and non-rated, including frame gasketing system
- Delete: 1.1.2 Panels
- Re-Number: 1.1.3 to 1.1.2 and substitute with:
 Sound retardant steel doors, swing type, flush, with or without glazed openings, fire-rated and non-rated, including door bottom gasketing.
- Substitute: 1.2.7 Steel doors and frames 08 11 13
- Delete: 1.2.11 Weatherstripping and gasketing
 1.2.13 Louvers and vents
 1.2.16 Assembly of knocked-down or slip-on frames
- Re-Number: 1.2.12 through 1.2.20 to 1.2.11 through 1.2.17
- Substitute: 1.4.3 ASTM E90-04, Standard Test Method for Laboratory Measurement of Airborne Sound Transmission Loss of Building Partitions and Elements
 1.4.4 ASTM E413-04, Classification for Rating Sound Insulation
- Delete: 1.4.5 ASTM C591
 1.4.6 ASTM C592
 1.4.7 ASTM C1289
 1.4.10 CGSB 41-GP-19MA
- Re-Number: 1.4.8 through 1.4.14 to 1.4.5 through 1.4.10
- Substitute: 1.5.3 Indicate material thickness, mortises, reinforcements, anchorages, locations of exposed fasteners, glazed or paneled openings, and arrangement of standard hardware.
- 2.1.3.1 Sound Retardant Composite
 Core materials for such units shall be manufacturer's proprietary standard, tested as part of a fully operable assembly, including door, frame and gasketing system, in accordance with ASTM E90 and ASTM E413 to provide the Sound Transmission Class (STC) and sound Transmission Loss (TL) values within the critical frequency range, as specified by the [Architect] [Acoustic Consultant].
- Delete: 2.1.3.2 Fiberglass
 2.1.3.3 Polystyrene
 2.1.4 Door Core Materials - Optional
- Re-Number: 2.1.5 to 2.1.4
- Delete: 2.1.6 Miscellaneous
 2.2.1.1 Spec Note referencing 14 Gauge Knocked-Down Frames

- Substitute: 2.2.1.1 Frame product shall be manufacturer's proprietary standard construction, tested as part of a fully operable assembly, including door, frame, glazing and gasketing system, in accordance with ASTM E90 and ASTM E413 to provide the Sound Transmission Class (STC) and sound Transmission Loss (TL) values within the critical frequency range, as specified by the [Architect] [Acoustic Consultant].
- 2.2.1.5 Provide appropriate anchorage to floor and wall construction. Quantities, types and locations of wall anchorage shall be as per manufacturer's proprietary design.
- Delete: 2.2.1.6 Minimum component gauges
- Re-Number: 2.2.1.7 to 2.2.1.6 and substitute:
 Frame product shall be prepared for and supplied complete with manufacturer's proprietary design of frame gasketing system.
- Re-Number: 2.2.1.8 and 2.2.1.9 to 2.2.1.7 and 2.2.1.8
- Substitute: 2.2.2.2 Corner joints shall be securely welded as per the manufacturer's proprietary construction.
- 2.2.2.3 Joints at mullions, sills and center rails shall be securely welded as per the manufacturer's proprietary construction.
- Delete: 2.2.2.8 Field Splices
- Re-Number: 2.2.2.9 to 2.2.2.8
- Delete: 2.2.3 Knocked-Down Type
- 2.2.4 Slip-On Type
- 2.3 Reference to ".1 General"
- 2.3.1.1 Spec Note on Construction Types
- Re-Number: 2.3.1.1 to 2.3.1 and substitute:
 Doors shall be manufacturer's proprietary construction, tested as part of a fully operable assembly, including door, frame, glazing and gasketing system, in accordance with ASTM E90 and ASTM E413 to provide the Sound Transmission Class (STC) and sound Transmission Loss (TL) values within the critical frequency range, as specified by the [Architect] [Acoustic Consultant].
- Delete: 2.3.1.2 Interior doors
- 2.3.1.3 Spec Note on Longitudinal Edges
- 2.3.1.3 Longitudinal Edges
- Re-Number: 2.3.1.4 through 2.3.1.6 to 2.3.2 through 2.3.4
- Delete: 2.3.1.7 Top and Bottom Channels
- 2.3.1.8 Minimum Component Gauges
- Re-Number: 2.3.1.9 through 2.3.1.11 to 2.3.5 through 2.3.7
- Delete: 2.3.2 Laminated Core Construction
- 2.3.3 Welded Stiffener Construction
- Substitute: 3.2 *SPEC NOTE reference to Slip-On type frames with:
 Refer to manufacturer's installation instructions for detailed recommendations.*
- 3.2.14 Install glazing.
- Delete: From Table 1;
 - Frames
 - Doors

END OF SECTION 08 34 73

**SPECIFICATIONS - SECTION 08 39 53
 BLAST RETARDANT STEEL DOOR AND FRAME ASSEMBLIES**

SPEC NOTE: When compiling Specifications for blast retardant steel door and frame assemblies, modify the CSDMA, "Recommended Specifications for Commercial Steel Door and Frame Products", Section 08 11 13, Parts 1 through 3 as indicated below.

- Substitute: Section Heading "08 11 13" with:
 08 39 53
 Section Name "STEEL DOORS AND FRAMES" with:
 BLAST RETARDANT STEEL DOOR AND FRAME ASSEMBLIES
- Part 1 Spec Note reference to the CSDMA "Selection and Usage Guide"
- 1.1.1 Blast retardant steel frames, fire-rated and non-rated.
- Delete: 1.1.2 Panels
- Re-Number: 1.1.3 to 1.1.2 and substitute:
 Blast retardant steel doors, swing type, flush, with or without glazed openings, fire-rated and non-rated, including hanging, latching hardware and glazing materials.
- Delete: 1.2.2 Building in frames in stud walls
- Re-Number: 1.2.3 through 1.2.8 to 1.2.2 through 1.2.7
- Re-Number: 1.2.9 to 1.2.8 and substitute:
 Steel Doors and Frames 08 11 13
- Delete: 1.2.10 Builders hardware
 1.2.12 Glass and glazing materials
 1.2.13 Louvers and vents
 1.2.16 Assembly of knocked-down or slip-on frames
- Re-Number: 1.2.11 through 1.2.20 to 1.2.9 through 1.2.15
- Substitute: 1.4.3 ASTM E330-02, Standard Test Method for Structural Performance of Exterior Windows, Doors, Skylights and Curtain Walls by Uniform Static Air Pressure Difference
- Delete: 1.4.4 ASTM C578
 1.4.5 ASTM C591
 1.4.6 ASTM C592
 1.4.7 ASTM C1289
 1.4.9 CAN4-S106
 1.4.10 CGSB 41-GP-19MA
 1.4.13 CSDMA, Selection and Usage Guide
- Re-Number: 1.4.8 through 1.4.14 to 1.4.4 through 1.4.7
- Substitute: 1.5.3 Indicate material thickness, mortises, reinforcements, anchorages, locations of exposed fasteners, glazed or paneled openings, and arrangement of standard hardware.
- Add: 1.5.4 Submit test or engineering data and installation instructions.
- Re-Number: 1.5.4 through 1.5.6 to 1.5.5 through 1.5.7
- Substitute: 2.1.3.1 Blast Retardant Composite
 Core materials for such units shall be manufacturer's proprietary standard, tested and/or engineered as part of a fully operable assembly, including door, frame,

glazing, gasketing and hardware in accordance with ASTM E330 to provide the blast resistance specified by the Architect or Consultant.

- Delete: 2.1.3.2 Fiberglass
- 2.1.3.3 Polystyrene
- 2.1.4 Door Core Materials - Optional
- Re-Number: 2.1.5 to 2.1.4
- Delete: 2.1.6 Miscellaneous
- 2.2.1 Spec Note on Frame Products
- Substitute: 2.2.1.1 Spec Note on 14 Gauge KD Frames and references to the CSDMA, "Selection and Usage Guide"
- 2.2.1.1 Frames shall be manufacturer's proprietary standard construction, tested and/or engineered as part of a fully operable assembly, including door, frame, gasketing and hardware in accordance with ASTM E330 to provide the blast resistance specified by the Architect or Consultant.
- 2.2.1.5 Provide appropriate anchorage to floor and wall construction. Quantities, types and locations of wall anchorage shall be as per manufacturer's proprietary design.
- Delete: 2.2.1.6 Minimum Component Gauges
- Re-Number: 2.2.1.7 to 2.2.1.6 and substitute:
 Frames shall be prepared for and supplied complete with manufacturer's proprietary design of frame gasketing system, where required.
- Re-Number: 2.2.1.8 to 2.2.1.7
- Re-Number: 2.2.1.9 to 2.2.1.8 and substitute:
 Fire-rated frames shall be provided for those openings requiring fire protection as determined and scheduled by the Architect. Frames shall be listed for conformance with CAN4-S104. All fire-rated frames shall bear the label of, and be listed by a nationally recognized testing agency having a factory inspection service. Labeling shall be in accordance with NFPA 80, the listing authority's policies and label materials, and shall identify the manufacturer. Fire-rated frames shall be constructed as listed for labeling in the Follow-Up Service Procedures/Factory Inspection Manuals issued by the listing agency to individual manufacturers.
- Delete: 2.2.2.2 Spec Note
- 2.2.2.2 Corner Joints
- 2.2.2.3 Joints at Mullions, Sills and Center Rails
- 2.2.2.7 Glazing Stops
- 2.2.2.8 Field Splices
- Re-Number: 2.2.2.4 through 2.2.2.9 to 2.2.2.2 through 2.2.2.5
- Delete: 2.2.3 Knocked-Down Type
- 2.2.4 Slip-On Type
- 2.3 Reference to ".1 General"
- 2.3.1 Spec Note
- Re-Number: 2.3.1.1 to 2.3.1 and substitute:
 Doors shall be manufacturer's proprietary construction, tested and/or engineered as part of a fully operable assembly, including door, frame, glazing, gasketing and hardware in accordance with ASTM E330 to provide the blast resistance specified by the Architect or Consultant.

- Delete: 2.3.1.2 Interior Doors
2.3.1.3 Spec Note on Longitudinal Edge Seams
2.3.1.3 Longitudinal Edge Seams
- Re-Number: 2.3.1.4 through 2.3.1.6 to 2.3.2 through 2.3.4
- Re-Number: 2.3.1.7 to 2.3.5 and substitute:
Top and bottom of doors shall be provided with inverted, recessed, welded channels and flush steel top and bottom caps as per manufacturer's proprietary design.
- Delete: 2.3.1.8 Minimum Component Gauges
- Re-Number: 2.3.1.9 through 2.3.1.11 to 2.3.6 through 2.3.8
- Delete: 2.3.2 Laminated Core Construction
2.3.3 Welded Stiffener Construction
- Substitute: 3.2.14 Install glazing
- Delete Table 1

END OF SECTION 08 39 53

TABLE 1 - MINIMUM STEEL GAUGES FOR COMPONENT PARTS

		Gauge No. ^(*3)	
Frames	Extra-Heavy and Heavy Duty	14	
	Medium Duty	16	
	Standard Duty	18	
Doors	Laminated Core Construction:		
	Face Sheets	Extra-Heavy Duty	16 ^(*1) or 14 ^(*1)
		Heavy Duty	18 ^(*1) , 16 or 14
		Medium Duty	20 or 18
		Standard Duty	20
	Vertical Stiffeners	20	
	Welded Stiffener Construction:		
	Face Sheets	Extra-Heavy Duty	16 ^(*2) or 14 ^(*2)
		Heavy Duty	18 ^(*2)
	Vertical Stiffeners	20	
Accessories (Doors and Frames):			
	Lock and Strike Reinforcements	16	
	Hinge Reinforcements	12	
	Flush Bolt Reinforcements	16	
	Reinforcements for Surface Applied Hardware	18	
	Top and Bottom Channels	18	
	Steel Top Caps	20	
	Glass Trim (Screw Fixed or Snap-In Types)	20	
	Mortar Guard Boxes	22	
	Floor Anchors	16	
	Wall Anchors:		
	Masonry Strap Type	18	
	Masonry Wire Type	4.0 mm (0.156") dia.	
	Masonry Stirrup-Strap Type	16	
	Steel/Wood Stud Type	20	
	Steel/Wood Stud Tension and Associated Wall Type	20	
	Existing Masonry /Concrete Wall Type	20	
	Jamb Spreaders	20	

*1 : With adhesive assisted, tack-welded or continuously welded edge seams

*2 : Includes lock-seam edge doors with adhesive assisted, tack-welded or continuously welded edge seams

*3 : Refer to Appendix 1 of the CSDMA, "Recommended Specifications for Commercial Steel Door and Frame Products", for decimal inch and millimeter thickness and tolerances

APPENDIX 1: STEEL THICKNESSES AND GAUGES

The Tables below provide equivalent thickness information for coated (galvannealed and galvanized) sheet steel complying with ASTM A653/A653M, and stainless steel complying with ASTM A666, as they relate to traditionally specified steel gauges, based on standards published by the American Iron and Steel Institute (A.I.S.I.).

Coated (Galvannealed and Galvanized) Steel Sheet - CS, Type B						
Gauge	Nominal Equivalent Thickness		A.I.S.I. Tolerances (+/-)		Minimum Thickness ^(*1)	
	Imperial	SI	Imperial	SI	Imperial	SI
10	0.138"	3.51 mm	0.009"	0.23 mm	0.129"	3.28 mm
12	0.108"	2.74 mm	0.009"	0.23 mm	0.099"	2.51 mm
14	0.078"	1.98 mm	0.008"	0.20 mm	0.070"	1.78 mm
16	0.063"	1.60 mm	0.006"	0.15 mm	0.057"	1.45 mm
18	0.051"	1.30 mm	0.005"	0.13 mm	0.046"	1.17 mm
20	0.039"	1.00 mm	0.004"	0.10 mm	0.035"	0.90 mm
22	0.033"	0.84 mm	0.004"	0.10 mm	0.029"	0.74 mm

*1: Minimum = Nominal Thickness - Tolerance

Stainless Steel Sheet - Cold Worked						
Gauge	Nominal Equivalent Thickness		A.I.S.I. Tolerances (+/-)		Minimum Thickness ^(*1)	
	Imperial	SI	Imperial	SI	Imperial	SI
10	0.134"	3.40 mm	0.006"	0.15 mm	0.128"	3.25 mm
12	0.103"	2.62 mm	0.005"	0.13 mm	0.098"	2.49 mm
14	0.074"	1.88 mm	0.004"	0.10 mm	0.070"	1.78 mm
16	0.059"	1.50 mm	0.003"	0.08 mm	0.056"	1.42 mm
18	0.047"	1.19 mm	0.003"	0.08 mm	0.044"	1.11 mm
20	0.035"	0.89 mm	0.002"	0.05 mm	0.033"	0.84 mm
22	0.029"	0.74 mm	0.002"	0.05 mm	0.027"	0.69 mm

*1: Minimum = Nominal Thickness - Tolerance

APPENDIX 2: WELDED TYPE FRAMES

The illustrations below define the requirements for the three (3) Welded Type constructions referenced in the CSDMA frame product specifications for corner joints.

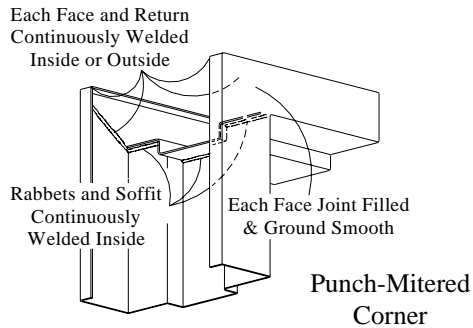

Profile Welded

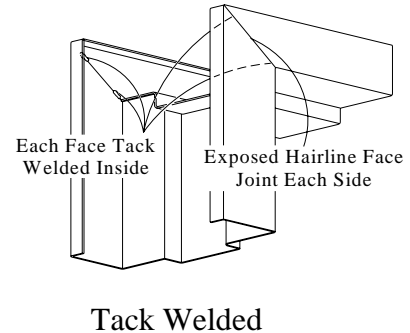
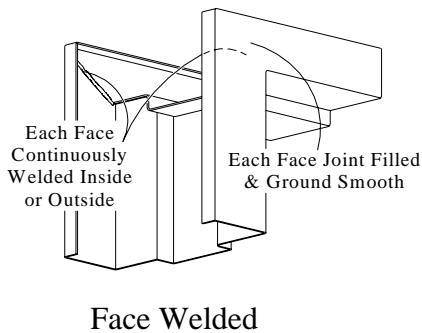
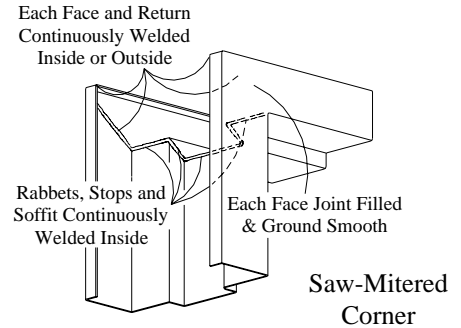

The following illustrate 'flush' and 'recessed' component welding requirements defined in the CSDMA frame product specifications for joints at mullions, sills and center rails. Concealed welded reinforcement design for 'recessed' applications varies by member manufacturer.

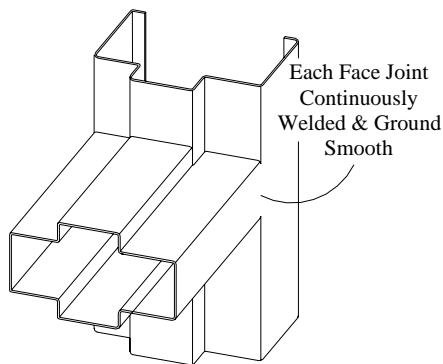

Flush Face Joints at Mullion,
Sill or Center Rail Intersections

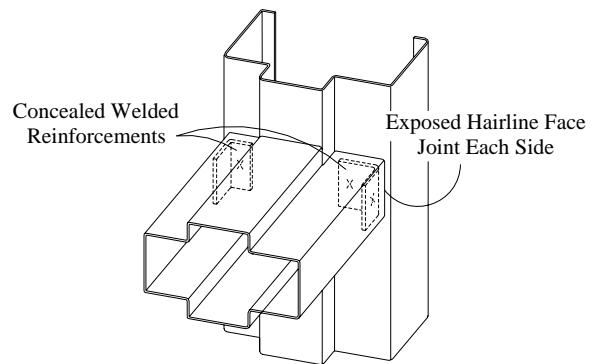

Recessed Face Joints at Mullion,
Sill or Center Rail Intersections

The requirements for fire-rated frame product varies by member manufacturer, and may supercede those indicated above. Consult individual members to determine limitations.

CSDMA Membership

All Steel Doors 2000 Limited

130 Milner Avenue
Scarborough, Ontario M1S 3R3
Tel: (416) 297-8500
Toll Free: (877) 353-0937
Fax: (416) 297-0374
E-Mail: sales@asddoors.com

Ambico Limited

1120 Cummings Avenue
Ottawa, Ontario K1J 7R8
Tel: (613) 746-4663
Toll Free: (888) 423-2224
Fax: (800) 465-8561
E-Mail: specialized@ambico.com
Website: www.ambico.com

Apex Industries, Inc.

100 Millennium Blvd.
Moncton, New Brunswick E1C 8M6
Tel: (506) 857-1600
Fax: (506) 857-1604
E-Mail: rlkelly@apexindustries.com
Website: www.apexindustries.com

Artek Door (1985) Limited

1294 South Service Road West
Oakville, Ontario L6L 5T7
Tel: (905) 842-6695
Toll Free: (888) 315-3667
Toll Free Fax: (888) 882-7835
E-Mail: sales@artekdoor.com
Website: www.artekdoor.com

Baron Metal Industries Inc.

101 Ashbridge Circle
Woodbridge, Ontario L4L 3R5
Tel: (416) 749-2111
Toll Free: (877) 777-9354
Fax: (905) 851-8346
E-Mail: sales@baronmetal.com
Website: www.baronmetal.com

Daybar Industries Limited

1235 Aerowood Drive
Mississauga, Ontario L4W 1B9
Tel: (905) 625-8000
Toll Free: (888) 332-9227
Fax: (905) 625-4204
E-Mail: sales@daybar.com
Website: www.daybar.com

Fleming Door Products Ltd.

20 Barr Road
Ajax, Ontario L1S 3X9
Tel: (905) 683-3667
Toll Free: (800) 263-7515
Fax: (905) 427-1668
E-Mail: postmaster@flemingdoor.com
Website: www.flemingdoor.com

Gensteel Doors

4950 Hickmore Street
St. Laurent, Quebec H4T 1K6
Tel: (514) 733-3562
Toll Free: (866) 436-7833
Fax: (514) 733-1932
E-Mail: sales@gensteeldoors.com
Website: www.gensteeldoors.com

Greensteel Industries Ltd.

975 Logan Avenue
Winnipeg, Manitoba R3E 1P3
Tel: (204) 774-4533
Fax: (204) 786-5899
Website: www.allmar.com

Metal Door Limited

P.O. Box 638
Gormley, Ontario L0H 1G0
Tel: (905) 888-5151
Fax: (905) 888-0647
E-Mail: info@metaldoorltd.com
Website: www.metaldoorltd.com

M. J. Daley Manufacturing Co. Ltd.

425 Comstock Road
Scarborough, Ontario M1L 2H4
Tel: (416) 752-2030
Toll Free: (888) 423-2539
Fax: (416) 752-6002
Toll Free Fax: (888) 899-9883
E-Mail: mjdaley@interlog.com

Shanahan's Manufacturing Ltd.

2731 - 57th Avenue S.E.
Calgary, Alberta T2C 0B2
Tel: (403) 279-2890
Toll Free: (800) 661-8420
Fax: (403) 203-3345
E-Mail: sales@shanahans.com
Website: www.shanahans.com

Trillium Steel Doors Limited

98 Stafford Drive
Brampton, Ontario L6W 1L4
Tel: (905) 452-1333
Fax: (905) 452-9475
E-Mail: info@trilliumdoors.com
Website: www.trilliumdoors.com

CANADIAN
STEEL DOOR
MANUFACTURERS
ASSOCIATION

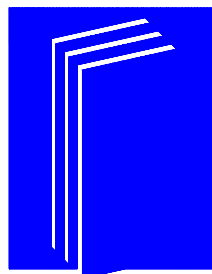

L'ASSOCIATION
CANADIENNE
DES FABRICANTS
DE PORTES

One Yonge Street, Suite 1801, Toronto, Ontario, M5E 1W7
Tel: (416) 363-7845 · Fax: (416) 369-0515 · E-Mail: info@csdma.org · Website: www.csdma.org